

⚡ Specifications

Nominal Voltage(V)

12V

Nominal Capacity

10 hour rate	(13A to 10.80V)	130Ah
5 hour rate	(22.1A to 10.20V)	110.5Ah
1 hour rate	(78A to 9.60V)	78Ah

Weight

Approx. 42.6kg(93.7Lbs.)

Internal Resistance (at 1KHz)

Approx. 5 mΩ

Maximum Discharge Current for

5 seconds: 1300A

Charging Methods at 25°C(77°F)

Maximum Charging Current :	39A
Standby use:	
Float Charging Voltage	13.5 to 13.8V
Coefficient -3.0mV/°C/cell	

Operating Temperature Range

Charge	-15°C(5°F) to 40°C(104°F)
Discharge	-15°C(5°F) to 50°C(122°F)
Storage	-15°C(5°F) to 40°C(104°F)

Charge Retention (shelf life) at 20°C(68°F)

1 month	98%
3 month	94%
6 month	85%

Case Material

ABS UL94 HB
Option: Flammability resistance of (UL94 V-0)

Design Life & Standard

EUROBAT(20°C) : >12 YEARS VERY LONG LIFE

Terminal

F18



⚡ Dimensions

Length (L)	483±3 (19.02±0.12)
Width (W)	170±3 (6.69±0.12)
Height (H)	240±3 (9.45±0.12)
Overall Height (HT)	240±3 (9.45±0.12)

Description of torque value of hardware for the terminals:

Recommended torque value	M8: 12 N-m (122 kgf-cm)
Maximum allowable torque value	M8: 20 N-m (204 kgf-cm)

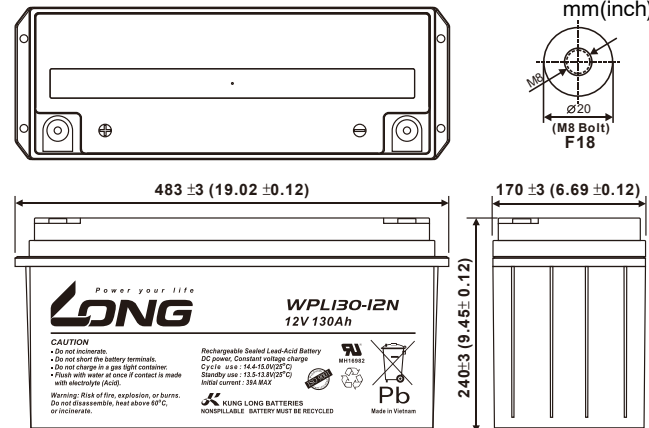

Discharge Time VS. Discharge Current (25°C)

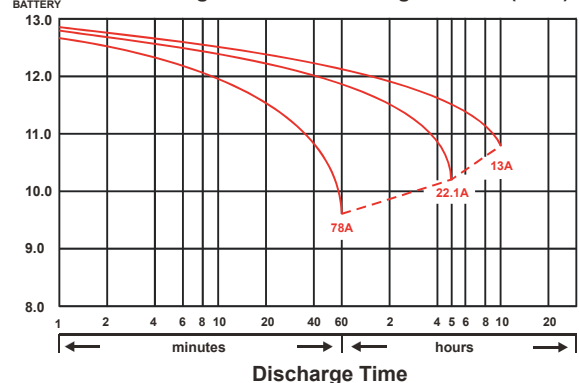

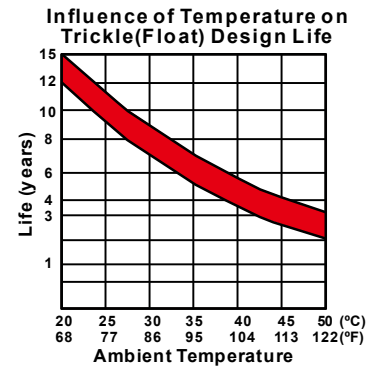
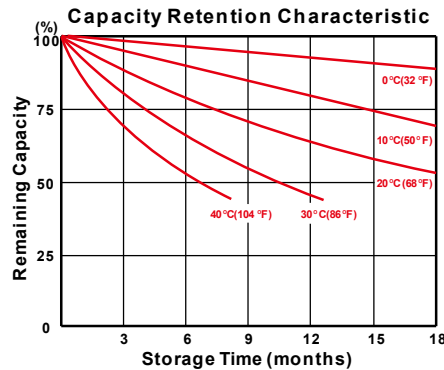
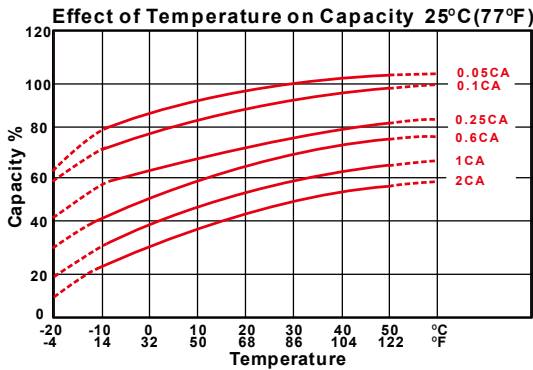

- PERFORMANCE DATA

Discharge Rates in Watts to Various End Voltages at 25°C(77°F)

End Voltage		1.85V	1.80V	1.75V	1.70V	1.67V	1.65V	1.60V
5	min	425	442	537	580	614	633	673
10	min	315	368	450	472	497	510	533
15	min	307	345	357	371	388	396	411
20	min	275	289	301	315	327	333	345
30	min	221	230	237	245	253	257	264
60	min	142	144	147	149	152	153	156
90	min	115	121	123	125	125	126	127
120	min	92.2	96.5	98.4	100	100	100	101
180	min	61.8	64.7	66.0	66.8	67.1	67.3	67.8
240	min	51.3	53.6	54.7	55.3	55.6	55.8	56.1
300	min	43.1	45.1	46.0	46.5	46.7	46.9	47.2
480	min	29.3	30.6	31.2	31.6	31.7	31.8	32.0
600	min	24.6	25.7	26.3	26.6	26.7	26.7	26.9
1200	min	13.3	13.9	14.2	14.3	14.4	14.4	14.5

- Discharge Rates in Amperes to Various End Voltages at 25°C(77°F)

End Voltage		1.85V	1.80V	1.75V	1.70V	1.67V	1.65V	1.60V
5	min	225	255	310	335	358	368	389
10	min	180	210	253	270	284	291	304
15	min	170	192	194	204	213	218	226
20	min	150	158	164	172	178	182	188
30	min	114	119	123	127	131	133	137
60	min	71.7	72.8	74.0	75.3	76.4	77.3	78.7
90	min	58.0	60.8	62.0	62.7	63.1	63.3	63.8
120	min	46.3	48.5	49.4	50.0	50.3	50.4	50.8
180	min	30.9	32.4	33.0	33.4	33.6	33.7	33.9
240	min	25.5	26.7	27.2	27.6	27.7	27.8	28.0
300	min	21.5	22.5	22.9	23.2	23.3	23.3	23.5
480	min	14.6	15.2	15.5	15.7	15.8	15.8	15.9
600	min	12.2	12.8	13.1	13.2	13.3	13.3	13.4
1200	min	6.60	6.89	7.04	7.12	7.14	7.16	7.19

All data on the spec. sheet is an average value:

The tolerance range : $X < 6\text{min}$ (+15%~-15%), $6\text{min} \leq X < 10\text{min}$ (+12%~-12%), $10\text{min} \leq X < 60\text{min}$ (+8%~-8%), $X \geq 60\text{min}$ (+5%~-5%)

201224-1L